



## SAL-U Series Hopper Loader

SAL-6U



Refer carefully to the manual before operation.

# SAL-U Series

## Coding Principle

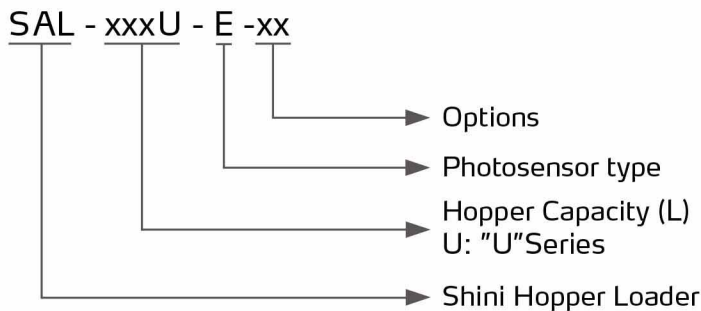

SAL-1U

## Features

- Compact and lightweight, and the high-speed carbon brush motor easy installation and superior vacuum.
- User-friendly extended wire controller. All models equipped with auto-purge function and a cloth filter.
- Preventive service alert for motor's carbon brush.
- Controller build-in proportional valve SPV-U control function.
- Left and right 360-degree base mounting.
- All models equipped with auto-purge function, a cloth filter, and purge alarm.



Air Accumulator

## Options

- Optional air accumulator for max auto-purge function (available on 6U/12U only). Add "A" at the end of the model code.
- Optional enhanced mixing technology for proportional valve SPV-U application. Add "QM" at the end of the model code.
- Optional internal polished hopper loader. Add "P" at the end of the model code.

## Conveying Capacity

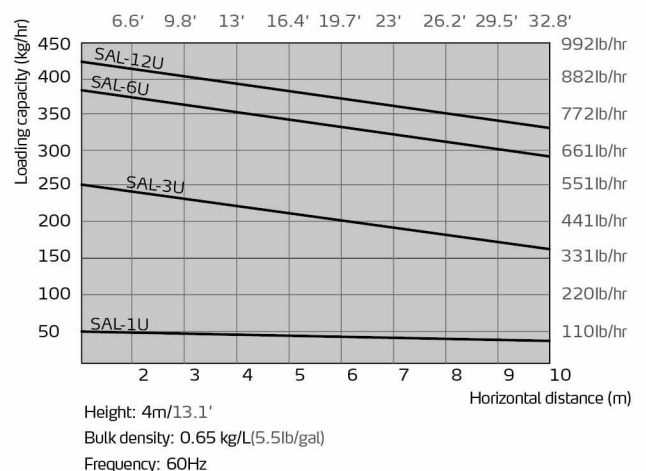
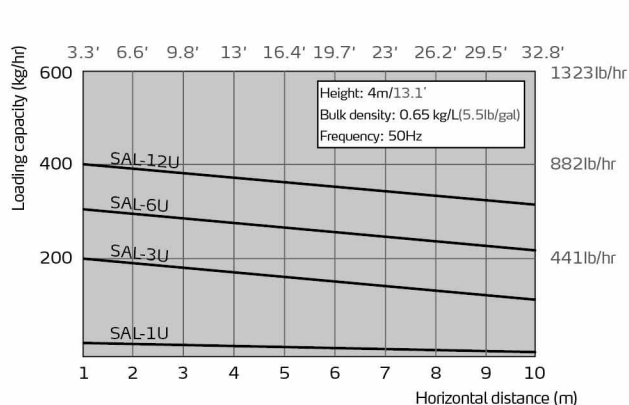

## Application

1. Photosensor Hopper Loader(SAL-U-E)
2. Hopper dryer
3. Vacuum Hopper Loader (SAL-U)
4. Material storage tank

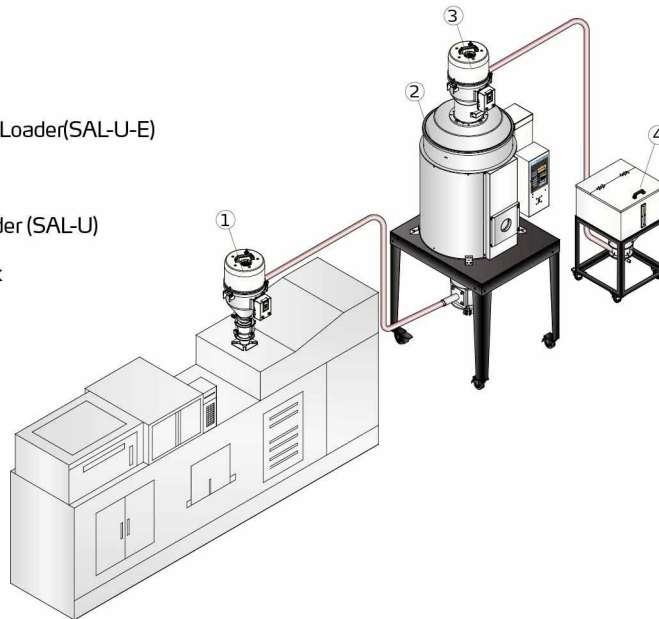

## Outline Drawings

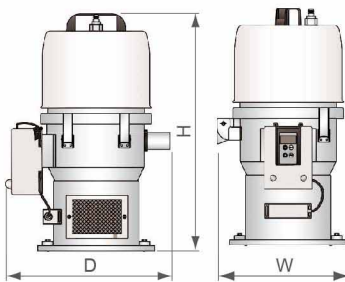

SAL-U

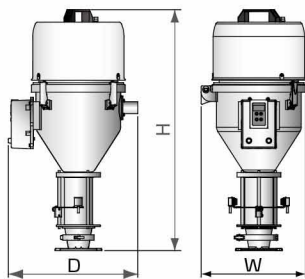

SAL-U-E

## Specifications

Model	SAL-1U	SAL-3U	SAL-6U	SAL-12U	SAL-1U-E	SAL-3U-E	SAL-6U-E	SAL-12U-E	
Motor Type	Carbon brush								
Motor Power (kW, 50/60Hz)	0.46/0.53		1.15/1.32		0.46/0.53		1.15/1.32		
Conveying Pipe Dia. (inch)	1.5	1.5	1.5	1.5	1.5	1.5	1.5	1.5	
Conveying Capacity	kg/hr	30	200	300	400	30	200	300	
	lb/hr	66	441	661	882	66	441	661	
Hopper Capacity	L	1	3	6	12	1.5	3	6	
	gal	0.26	0.79	1.59	3.17	0.4	0.79	1.59	
Hinge Hopper Cover	●	●	●	●	●	●	●	●	
Compress Air Purge	●	●	●	●	●	●	●	●	
Air Accumulator	-	-	○	○	-	-	○	○	
Dimension	H	mm	525	555	645	745	630	740	800
		inch	20.7	21.8	25.4	29.3	24.8	29.1	31.5
	W	mm	240	305	340	340	270	305	340
		inch	9.5	12	13.4	13.4	10.5	12	13.4
	D	mm	325	370	410	410	325	370	410
		inch	12.8	14.6	16.1	16.1	12.8	14.6	16.1
Weight	kg	10	11	12	14	11	13	16	
	lb	22	24.3	26.5	30.9	24.3	28.7	35.3	

Notes:1) Test condition of conveying capacity: plastic material of bulk density 0.65kg/L(5.5lb/gal), dia. 3-5mm/0.12-0.2inch, vertical conveying height: 4m/13.1Feet, horizontal conveying distance: 1m/3.28Feet.

2) Compressed air supply: 4-6kgf/cm<sup>2</sup>.

2) "●" stands for standard, "○" stands for options, "-" stands for none.

4) Power Supply: 1Φ, 115/230VAC, 50/60Hz

## Shini Group

Addr: No. 23, Minhe St., Shulin Dist.,  
New Taipei, Taiwan

Tel: +886 2 2680 9119

Fax: +886 2 2680 9229

Email: [shini@shini.com](mailto:shini@shini.com)

### Factories:

- Taiwan
- Dongguan
- Pinghu
- Ningbo
- Chongqing
- Pune