



## "Budget" Vertical Mixer

SVM-100-EB



Refer carefully to this manual before operation.

# SVM-EB Series

## ■ Coding Principle

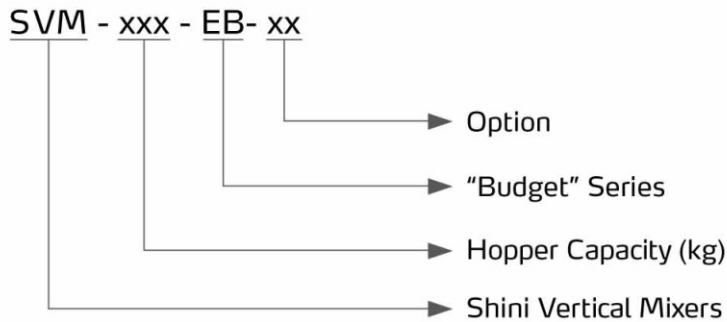

## ■ Features

- Stainless steel hopper receiver and mixing blade ensure no material contamination and durability.
- Hopper lid has protective device. Stop machine when open the hopper lid to avoid danger caused by misoperation.
- It equips with motor overload protection to avoid motor overload and burnout.
- Auto stop device is provided, and the auto stop function can be set within 0~300 hr.



Control Panel

## ■ Application

SVM-EB series are suitable for plastics mixing and blending, as blending for new material, regrind or powder, and they also can be used for mixing of unproportional new material and regrind.

## ■ Working Principle

SVM-EB series are driven by motor. As the rotation of blades, the materials are mixed and then be conveyed to corresponding containers, achieving the purpose of uniform mixing.

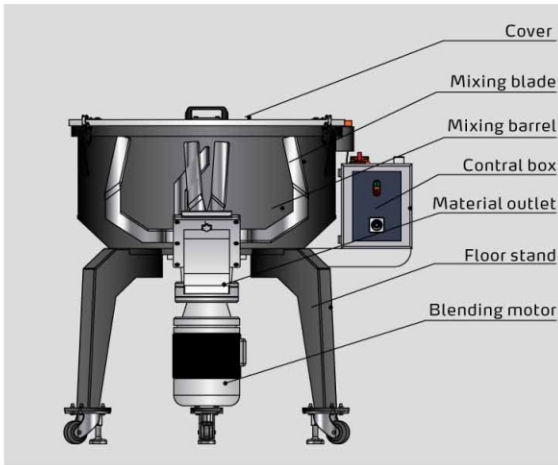

Control box sends signal to the motor, and it starts rotating. Motor main shaft drives blades to mix different materials with the rotation, which evenly mix the material in short cycle. When timer of the control box reaches set time, the motor stops. At this time, open the discharge port of the hopper, and discharge the material. Then, the mixing is finished (During the process, if the mixing is overloaded, the buzzer will sound with alarm).

## Outline Drawings

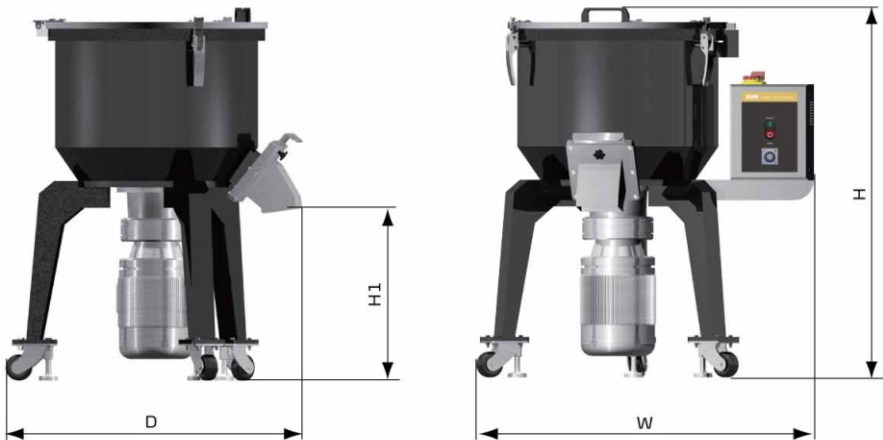

## Specifications

Model	SVM-25-EB	SVM-50-EB	SVM-100-EB	SVM-150-EB	SVM-200-EB	SVM-300-EB
Motor Power (kW)	1.1	1.5	3.0	4.0	7.5	7.5
Max. Throughput (kg/hr)	125	250	500	750	1000	1500
Blending Barrel* (kg)	25	50	100	150	200	300
Dimensions	H (mm)	920	1085	1115	1245	1610
	H1 (mm)	420	487	495	495	785
	D (mm)	830	861	1070	1070	1180
	W (mm)	935	965	1150	1150	1280
Weight(kg)	90	120	170	250	340	385

- Notes: 1) "\*" means when overloaded, the optimal mixing time is about 10 mins.  
 2) Maximum noise level is 80dB (A).  
 3) All output capacities from above models are based on data from bulk density 0.65Kg/L and 2-3 mm in size.  
 4) Maximum throughput is 5 batches in hourly mixing, with 10mins for each batch, which is calculated by maximum capacity of the hopper.  
 5) Power supply: 3 Φ 400VAC 50Hz

We reserve the right to change specifications without prior notice.

## Shini Group

Addr: No. 23, Minhe St., Shulin Dist.,  
New Taipei, Taiwan

Tel: +886 2 2680 9119

Fax: +886 2 2680 9229

Email: [shini@shini.com](mailto:shini@shini.com)

### Factories:

- Taiwan
- Dongguan
- Pinghu
- Ningbo
- Chongqing
- Pune

2017-02-15-04 Copyrights Reserved.

[www.shini.com](http://www.shini.com)