



Shredder

SGS-6080S



Refer carefully to this manual before operation.

SGS Series

■ Coding Principle

SGS - xx xxx S

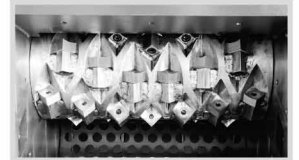

Cutters of Single-shaft Shredder

■ Features

- Milling smashing design, cutting in medium speed, low noise, low energy consumption, smashing in uniform size. Screen mesh will be chosen in accordance with customer's requirement.
- Rotor uses the square knife block of indentation on the surface to reduce the friction heat. When one of the angles of the cutter is broken, it can simply inter-change the cutter to improve the cutting efficiency.
- The automatically hydraulic device can be adjusted to achieve optimum production.
- Equipped with independent control panel, there are automatic and manual operational modes to choose, quite flexible and safe.
- Machine connects the transmission shaft and belt wheel through V-shape belt to make operating balance and dismantle convenient.
- Mount anti-vibration pads at the machine feet for reducing vibration during shredding.
- Have reverse alarm function for making the machine fail to start and flashing the alarm light when the power supply is mistakenly connected.
- Possess multiple protections, such as current relay and motor overload protection.



SGS-4860S

■ Option

When crushing hard and crisp materials, the materials are easy to pop up from the feeding port. Customers can select feeding boxes according to their demands to prevent splashed materials during the process.

■ Application

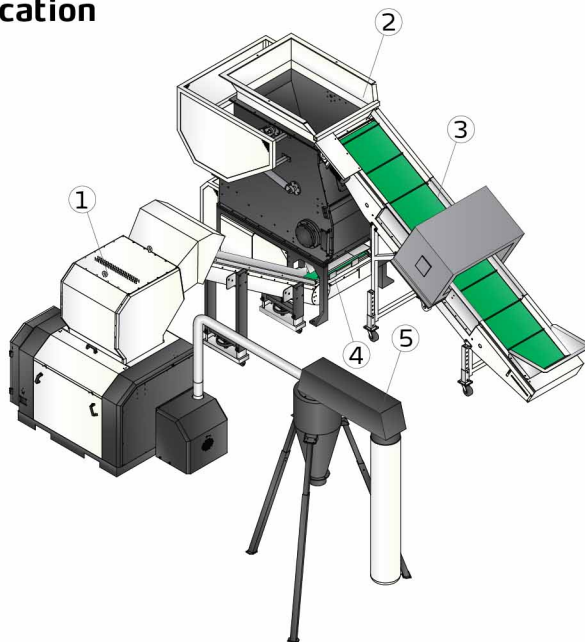

1. Sound-proof central granulator
2. Shredder
3. Belt conveyors with metal detector
4. Up-feed belt conveyor
5. Dust separator

Outline Drawings

Specifications

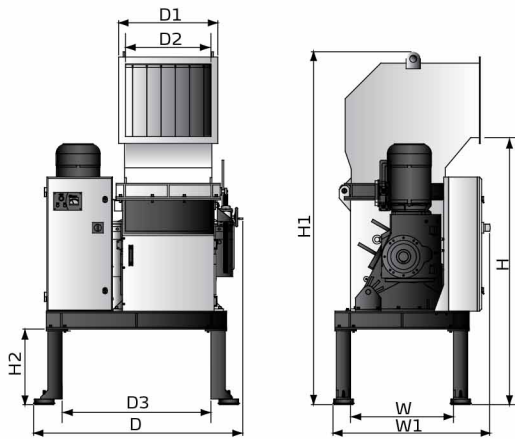

SGS-4860S

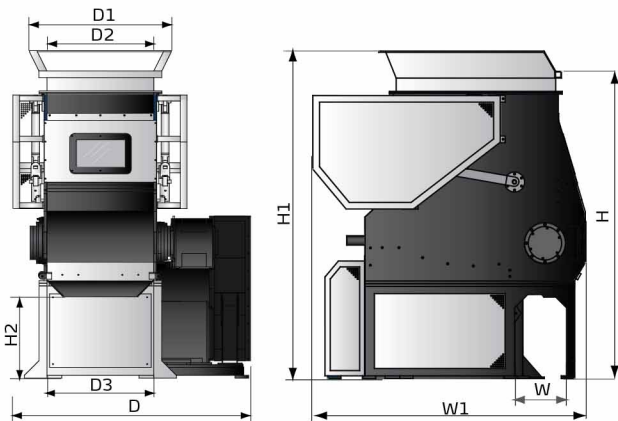

SGS-6080S/SGS-75120S

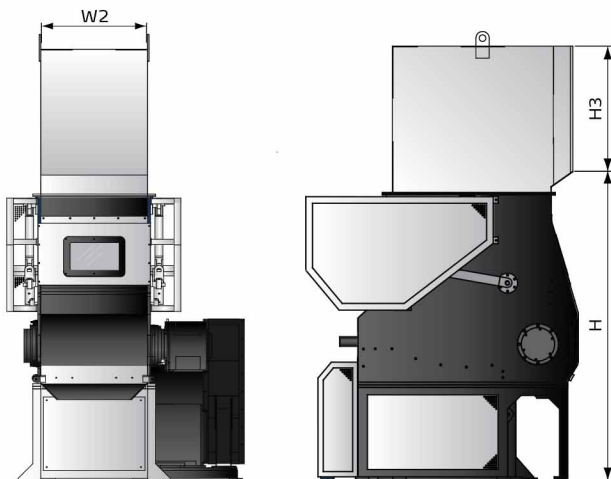

SGS-6080S/SGS-75120S(選裝進料箱)

Model	SGS-4860S	SGS-6080S	SGS-75120S		
Motor Power (kW, 50/60Hz)	15	37	55		
Speed of Main Shaft (rpm, 50/60Hz)	65	73	73		
Motor Power of Hydraulic System (kW)	-	3.7	3.7		
Material of Cutters	SKD11	SKD11	SKD11		
Number of Fixed Blades	2	4	6		
Number of Rotating Blades	39	57	93		
Cutting chamber size	mm	480 × 600	600 × 800	750 × 1200	
	inch	18.9 × 23.6	23.6 × 31.5	29.5 × 47.2	
Max Throughput Capacity (kg/hr, 50/60Hz)	400	1000	1500		
Noise Level dB(A)	110	110	110		
Dia. of Screen Hole (Φ30 mm)	√	√	√		
Dia. of Screen Hole	mm	○ Φ20, Φ25, Φ35			
	inch	○ Φ0.79, Φ0.98, Φ1.38			
Regrind Conveying Device	-	○	○		
Feed box	√	○	○		
Dimensions	H	mm	1900	2300	2560
		inch	74.8	90.6	100.8
	H1	mm	2500	2455	2715
		inch	98.4	96.7	106.9
	H2	mm	530	610	770
		inch	20.9	24	30.3
	H3	mm	-	940	1245
		inch	-	37	49
	W	mm	720	390	440
		inch	28.3	15.4	17.3
	W1	mm	1100	2040	2410
		inch	43.3	80.3	94.9
	W2	mm	-	790	1190
		inch	-	31.1	46.9
	D	mm	1450	1780	2226
		inch	57	70	88
	D1	mm	700	1060	1460
		inch	27.6	41.7	57.5
D2	mm	600	800	1200	
	inch	23.6	31.5	47.2	
D3	mm	1045	800	1200	
	inch	41.1	31.5	47.2	
Weight	kg	1620	3970	5500	
	lb	3,571	8,752	12,125	

Notes: 1) "√" standard, "○" Stands for options.

2) Max capacity of the machine is subject to diameter of screen mesh and composition of material. The above data is based on 5 mins continually shredding of PVC sprue, 300-500KG capacity generally ranges from 300-500kg for granulating piping tube.

3) Noise level will vary with different materials and motor types.

4) SKD11 are JIS code number.

5) For avoiding plastic to adhibit the blade, all materials should be crushed at normal temperature.

6) Power supply: 3Φ, 230 / 400 / 460 / 575VAC, 50 / 60Hz.

Shini Group

Addr: No. 23, Minhe St., Shulin Dist.,
New Taipei, Taiwan

Tel: +886 2 2680 9119

Fax: +886 2 2680 9229

Email: shini@shini.com

Factories:

- Taiwan
- Dongguan
- Pinghu
- Ningbo
- Chongqing
- Pune

2019-02-15-04 Copyrights Reserved.

www.shini.com