

Central Vacuum Generators

SCVG



Application

In central conveying system, central vacuum generator will provide vacuum (negative pressure) power. This machine adopts high pressure blower or Roots blower as its core power, which has features like heavy-duty, great power and long service life etc to ensure continuously loading. Besides, this series offer more than 11 models with maximum 15 HP applicable to different system applications. The start of the blower is controlled via central control station and can work with equipments like Euro vacuum central hopper and central filter to realize automatic material loading function.

Outline Drawings

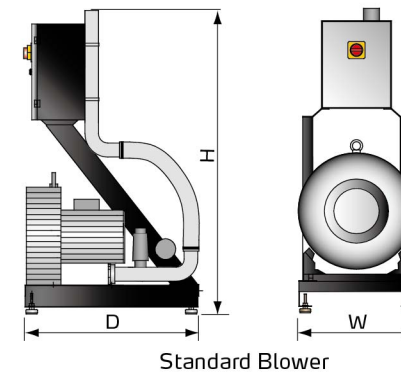

Standard Blower

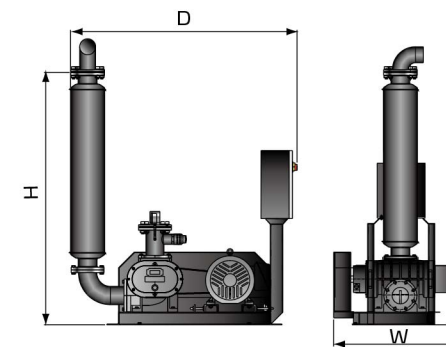

Roots Blower

Specifications

Model	Motor Power (kW, 50/60Hz)	Air Suction Pipe Dia. (Inch)	Dimensions (mm)H×W×D	Weight (kg)
SCVG-050-SS	3.4/3.7	2	1125×420×650	64
SCVG-050-DS			1125×653×650	
SCVG-100-SS	7.5/8.6	2.5	1220×540×700	106
SCVG-100-DS			1220×722×700	
SCVG-150-SS	9/11	2.5	1300×560×930	128

Note: 1) "SS" stands for single stage blower, "DS" stands for double stage blower.
2) Power supply: 3Φ, 230/400/460/575VAC, 50/60Hz.

Model	Motor Power (kW, 50/60Hz)	Air Suction Pipe Dia. (Inch)	Dimensions (mm)H×W×D	Weight (kg)
SRB-65-V	5.5/6.3	2	1158×631×1560	253
SRB-80-V	7.5/8.6	2.5	1363×725×1615	355
SRB-100-V	11/13	3	1448×816×1611	411
SRB-125-V	7.5-18/8.6-20.7	5	2000×900×1285	600
SRB-125A-V	11-22/13-25.3	5	2000×875×1285	640
SRB-150-V	15-30/17.2-34.5	6	2040×985×1300	680

Note: 1) "V" stands for vacuum.
2) Applicable to various kinds of motors.
3) Power supply: 3Φ, 230/400/460/575VAC, 50/60Hz.