



Standard Five Axes Servo Driven Robot

ST5-900-1600DT-S2



Refer carefully to this manual before operation.

ST5-S Series

■ Coding Principle

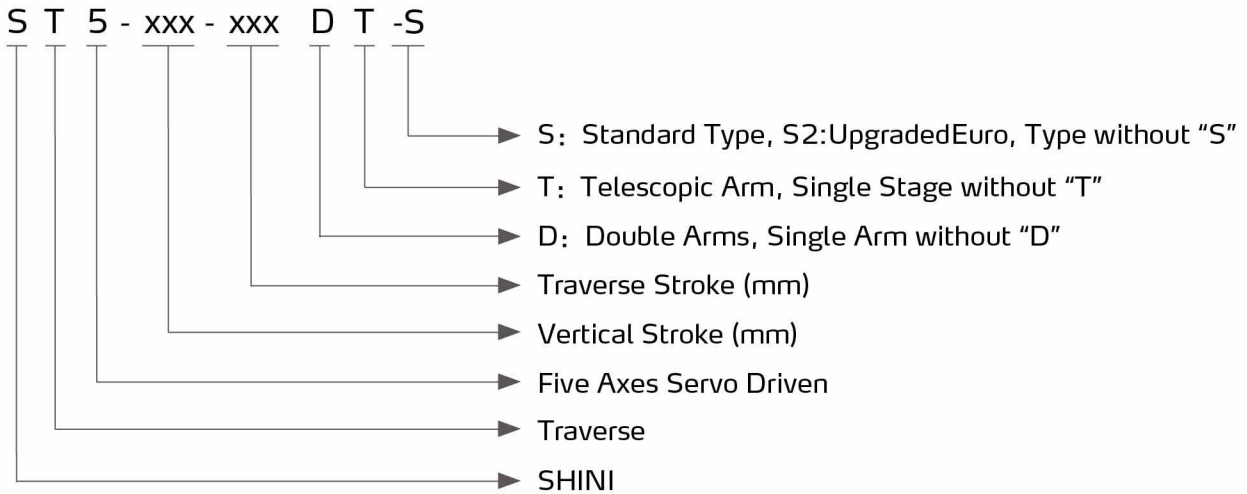

■ Features

● Precision

All linear movements are driven by heavy duty servo motors with cooperation of precise linear guide rails and high power V belts; fast, silent, and precise. Wrist mechanism employs pneumatic driven rack and pinion system, which accomplishes smooth, stabled and precise flipping motion. Vertical arm with telescopic design efficiently minimizes the cycle time and height of the robot.



Home Page

● Safety

Position limit sensors and blocks effectively prevent mechanical and electrical malfunctions. Control board with short circuit function.

● Intelligence

8.0 inch high definition TFT touch screen. 3-point switch for safer robot operation. CPU modularization, the operator, main control modular and extension modular has independent CPU, improve the system's respond and keep it safety. The hardware used multi-layer PCB and multi-rank high precision electrical modular, strong anti - interference ability. Hardware protect function, each signal output with intelligent detection, avoid short-circuit, overload and high temperature. Base on the VARAN BUS technology, the system can be extended, strong adaptability and flexibility. Teach modules with stacking and matrix locate functions, support conditional judgment, loop control, signal waiting and others logic instructions.

● User Friendly

Multi-languages system and reserved auxiliary equipment slots able to support our global clients' need.

■ Application

The ST5-S series robot is designed for rapid and precise removal of products from injection molding machine, and place them at desired locations. Standard and telescopic arm(s) are selectable to cooperate with 2-plate mold or hot runner system. Capable of arranging, stacking, quality checking and in mold placement. Suitable for injection molding machine under 300T clamp force.

ST5-S Series

Outline Drawings

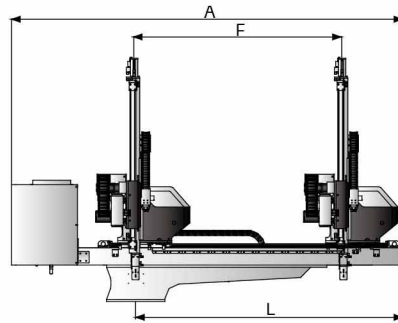
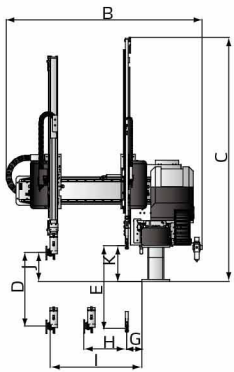

Five Axes Servo

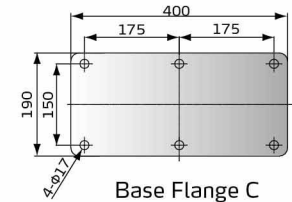

Base Flange C

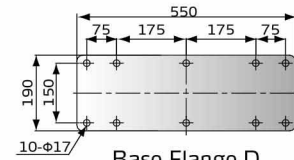

Base Flange D

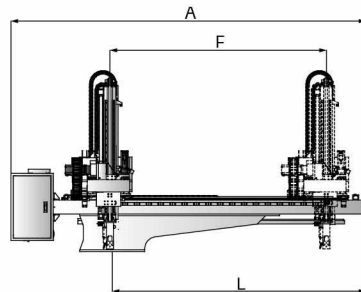
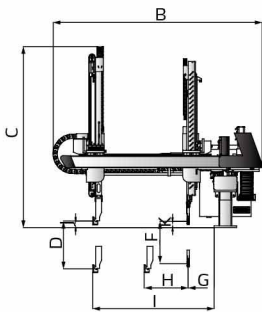

Five axes servo small telescopic (bracket type) robot arm

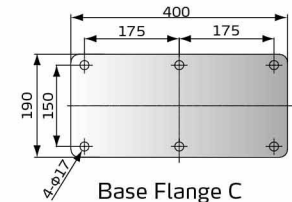

Base Flange C

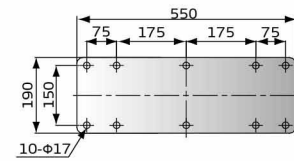

Base Flange D

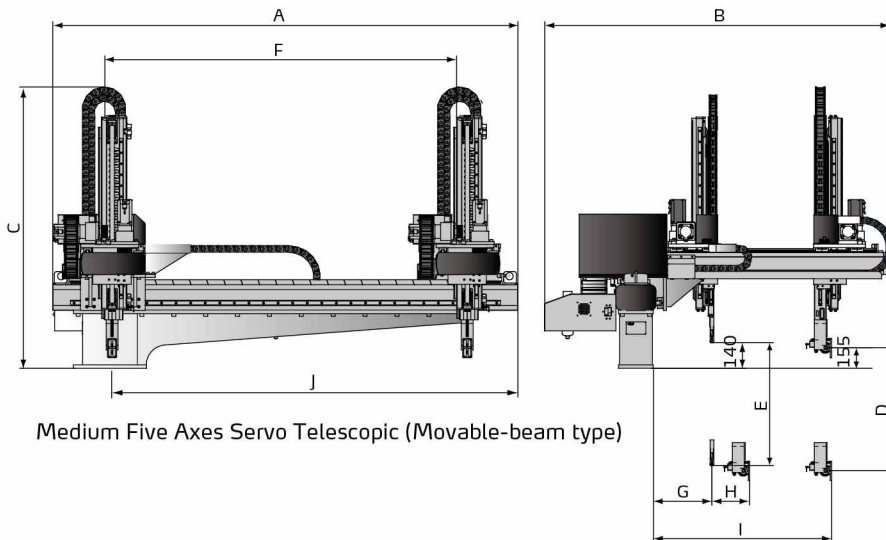

Medium Five Axes Servo Telescopic (Movable-beam type)

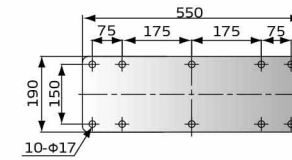

Base Flange



■ Specifications

Model(ST5)		700-1200D-S2	700-1400D-S2	900-1600DT-S2	1100-1800DT-S2
IMM (ton)		50-80	80-160	220-260	320-400
Traverse Stroke (mm)		1200	1400	1600	1800
Crosswise Stroke (mm)	Main Arm	370	370	370	650
	Sub Arm	370	370	370	650
Vertical stroke (mm)	Main Arm	700	700(800)	900(1000)	1100(1200)
	Sub Arm	750	750(850)	950(1050)	1100(1200)
Max Load (with tool) (kg)		3	3	5	6
Min Pick-out Time (sec)		1.3	1.3	1.3	1.5
Min Cycle Time (sec)		5.2	5.2	5.5	6.2
Air Pressure (bar)		4~6	4~6	4~6	4~6
Max. Air Consumption (NI/cycle) *		5	5	4	4
Weight (kg)		260	280	310	340
Base Type		Base C	Base C	Base C	Base D
Dimensions (mm)	A	1770	2600	2800	3010
	B	1250	1390	1490	1710
	C	1660	1590(1690)	1360(1410)	1550(1600)
	D	700	700(800)	900(1000)	1100(1200)
	E	750	750(850)	950(1050)	1100(1200)
	F	1200	1400	1600	1800
	G	145	145	185	160
	H	120	160	140	160
	I	580	650	700	1030
	J	190	120	50	60
	K	240	170	100	60
	L	1500	1820	2020	2150

- Notes: 1) "M" stands for middle mold detector. (suitable for three-plate mold.)
 "EM12" stands for EUROMAP 12 communication interface.
 "EM67" stands for EUROMAP 12 communication interface.
 "ABS" at the end of the model code stands for models of high precision.
 "N" stands for non-operation side, operation side without "N"
 2) Power supply: 1Φ, 200~240V, 50/60Hz.
 3) " * " Max. air consumption for vacuum device 60NI/min.

ST5-S Series

Model		ST5-1300-2000DT-S	ST5-1500-2200DT-S
IMM (ton)		450 ~ 650	650 ~ 850
Traverse Stroke (mm)		2000	2200
Crosswise Stroke (mm)	Main Arm	630	750
	Sub Arm	630	750
Vertical stroke (mm)	Main Arm	1300	1500
	Sub Arm	1350	1550
Max Load (with tool) (kg)		10	12
Min Pick-out Time (sec)		3.2	3.5
Min Cycle Time (sec)		9	9.5
Air Pressure (bar)		4 ~ 6	4 ~ 6
Max. Air Consumption (NI/cycle) *		5	5
Weight (kg)		810	930
Dimensions (mm)	A	2800	3000
	B	2020	2140
	C	1650	1750
	D (max)	1300	1500
	E (max)	1350	1550
	F (max)	2000	2200
	G (min)	245	245
	H (min)	170	170
	I (max)	1100	1220
	J	2700	2900

Notes: 1) "M" stands for middle mold detector. (suitable for three-plate mold.)
 "EM12" stands for EUROMAP 12 communication interface.
 "EM67" stands for EUROMAP 12 communication interface.
 "ABS" at the end of the model code stands for models of high precision.
 "N" stands for non-operation side, operation side without "N"
 2) Power supply: 1Φ, 200~240V, 50/60Hz.
 3) " * " Max. air consumption for vacuum device 60NI/min.

We reserve the right to change specifications without prior notice.

Shini Group

Addr: No. 23, Minhe St., Shulin Dist.,
New Taipei, Taiwan

Tel: +886 2 2680 9119

Fax: +886 2 2680 9229

Email: shini@shini.com

Factories:

- Taiwan
- Dongguan
- Pinghu
- Ningbo
- Chongqing
- Pune

2020-04-15-04 Copyrights Reserved.

www.shini.com